

Growth and Income Inequality: A Canonical Model*

Cecilia García-Peñalosa
GREQAM and CNRS

Stephen J. Turnovsky
University of Washington

Revised version
January 2005

Abstract

We develop an endogenous growth model with elastic labor supply, in which agents differ in their initial endowments of physical capital. In this framework, the growth rate and the distribution of income are jointly determined. The key equilibrating variable is the equilibrium labor supply. It determines the rate of return to capital, which in turn affects both the rate of capital accumulation and the distribution of income across agents. We then examine the impact of various structural shocks on growth and distribution. We find that faster growth is associated with a more unequal, contemporaneous distribution of income, consistent with recent empirical findings.

JEL Classification : O17, O40.

Keywords: endogenous growth, income inequality, elastic labor supply.

*García-Peñalosa would like to acknowledge the financial support received from the Institut d'Economie Publique (IDEP), Marseille. Turnovsky's research was supported in part by the Castor endowment at the University of Washington. The paper has benefited from seminar presentations at the University of California, Riverside, and the University of Kansas, as well as from the comments of an anonymous referee.

1. Introduction

The relationship between growth and income inequality has occupied the attention of the profession for some 50 years, since the appearance of Kuznets (1955) pioneering work, and is both important and controversial. Its controversy derives from the fact that it has been difficult to reconcile the different theories, especially since the empirical evidence has been inconclusive.

As detailed by Lundberg and Squire (2003), the empirical literature has tended to evolve in one of two directions. One line of research follows the tradition of Kuznets, and has tested the hypothesis that inequality is an inverse-U shaped function of the level of output, with ambiguous results; see Anand and Kanbur (1993). At issue here is whether more inequality enhances or inhibits the growth rate. This has been addressed by running regressions of growth rates on measures of inequality and examining the signs of the relevant regression coefficients. Early tests of this hypothesis by Alesina and Rodrik (1994), Persson and Tabellini (1994), Perotti (1996), and others obtain a negative relationship. The various explanations for this include: the political economy consequences of inequality (Alesina and Rodrik), the fact that inequality may harm investment in physical or human capital (Galor and Zeira, 1993; Aghion and Bolton, 1997), and the unequal distribution of natural resources (Gylfason and Zoega, 2003). Other studies find a positive, or at least more ambiguous, relationship; see e.g. Li and Zou (1998), Forbes (2000), and Barro (2000). In particular, Forbes finds a positive relationship when the short-term impact is considered. Barro finds a negative relationship between inequality and growth for poorer countries, but a positive relationship in the case of richer countries. Explanations for the positive relationship include: a positive relationship between inequality and higher tax rates to finance public education and human capital formation (Saint-Paul and Verdier 1993), the role of socio-economic stratification (Bénabou, 1996a), and the nature of technological progress (Galor and Tsiddon, 1997).

The alternative approach involves examining the determinants of growth and inequality as essentially interdependent processes. Lundberg and Squire (2003) introduce a number of factors that may potentially influence both inequality and growth and test for their joint significance. They

identify two factors that are likely to impact both variables in the same direction, thereby implying a positive relationship between income inequality and growth.¹

Despite the controversy, one thing is clear. An economy's growth rate and its income distribution are both endogenous outcomes of the economic system. They are therefore subject to common influences, both with respect to structural changes as well as macroeconomic policies. Structural changes that affect the rewards to different factors will almost certainly affect agents differentially, thereby influencing the distribution of income. Likewise, policies aimed at achieving distributional objectives are likely to impact the aggregate economy's productive performance. Being between endogenous variables, the income inequality-growth relationship – whether positive or negative – will reflect the underlying common forces to which they are both reacting, and this can be understood only within the context of a consistently specified general equilibrium growth model.

The purpose of this paper is to develop a small canonical growth model in which the growth rate and income inequality are jointly determined. The framework we adopt is an extension of Romer's (1986) endogenous growth model with endogenous labor supply, with the heterogeneity of the agents, which is the source of the income inequality, stemming from their initial distribution of capital endowments. The key mechanism generating the endogenous distribution of income is the positive equilibrium relationship we derive between agents' relative wealth (capital) and their relative allocation of time between work and leisure. This relationship is very basic and has a simple intuition. Wealthier agents have a lower marginal utility of wealth. They therefore choose to increase consumption of all goods including leisure, and reduce their labor supply. Given their relative capital endowments, this translates to an endogenously determined distribution of income.

Indeed, the role played by labor supply in this model is analogous to its role in other models of capital accumulation and growth, where it provides the crucial mechanism by which demand shocks influence the rate of capital accumulation. For example, in the standard Ramsey model, government consumption expenditure will generate capital accumulation if and only if labor is supplied elastically. With inelastic labor supply it will simply crowd out an equivalent amount of private consumption. The key factor is the wealth effect and the impact this has on the labor-leisure

¹ The two factors they identify are measures of civil liberty and openness.

choice. This mechanism is also central to empirical models of labor supply based on intertemporal optimization; see e.g. MaCurdy (1981).

There is substantial empirical evidence documenting the negative relationship between wealth and labor supply. Holtz-Eakin, Joulfaian, and Rosen (1993) find evidence to support the view that large inheritances decrease labor participation. Cheng and French (2000) and Coronado and Perozek (2003) use data from the stock market boom of the 1990s to study the effects of wealth on labor supply and retirement, finding a substantial negative effect on labor participation. Algan, Chéron, Hairault, and Langot (2003) use French data to analyze the effect of wealth on labor market transitions, and find a significant wealth effect on the extensive margin of labor supply. Overall, these studies and others provide compelling evidence in support of the wealth-leisure mechanism being emphasized in this paper.

An attractive feature of the Romer (1986) model for our purposes is that this crucial labor supply function turns out to be linear in the agents' capital endowments. This makes the aggregation from individuals to the aggregate – critical to the study of income distribution within a consistently derived macro equilibrium – surprisingly tractable. Indeed, we are able to represent the macroeconomic equilibrium in terms of a simple recursive structure. First the equilibrium mean growth rate and labor supply are jointly determined to ensure that rates of return are in equilibrium and that the product market clears. The equilibrium values of these two variables are not affected by the distribution of wealth. Second, given the initial distribution of capital among agents, the equilibrium labor supply determines the degree of income inequality.

Using this framework, we analyze the joint determination of the growth rate and income inequality and consider how this responds to various structural changes pertaining to such things as the rate of time preference, productivity, and risk. On balance, our results tend to support the view that growth-enhancing structural changes are likely to be associated with higher income equality, consistent with the recent empirical findings of Li and Zou (1998), Forbes (2000) and Lundberg and Squire (2003).

We should also emphasize at the outset that by adapting the Romer model, we are ignoring other important elements central to the growth-income inequality relationship, most notably human

capital and education. This aspect is emphasized by Galor and Zeira (1993), Bénabou (1996b), and Viaene and Zilcha (2003), among others. By identifying agents' heterogeneity with their initial physical capital endowments, we are embedding distributional issues within a more traditional growth-theoretic framework. Indeed, the role of the return to capital, which is essential in that literature, has largely been ignored in the recent discussions of income inequality. The argument that the return to capital is essential to understanding distributional differences has, however, been emphasized by Atkinson (2003), and is supported by recent empirical evidence for the OECD (see Checchi and García-Peñalosa (2005)).

There is a substantial recent literature investigating the relationship between income distribution and growth. Of this literature, our paper is related to Alesina and Rodrik (1994), Persson and Tabellini (1994), and Bertola (1993), who develop AK growth models in which agents differ in their initial stocks of capital.² The first two papers have, however, a very different focus as they take initial inequality as given and argue that it has a negative impact on the rate of growth. In contrast to their results, this paper emphasizes that growth and distribution are jointly determined, and presents a possible mechanism that generates a positive relationship between these two variables in line with the evidence presented by Forbes (2000). Bertola (1993) is closer to our approach in that he emphasizes how technological parameters, specifically the productivity of capital, jointly determine distribution and growth. He also examines how policies directed at increasing the growth rate affect the distribution of consumption, although his assumption of a constant labor supply implies that the distribution of income is independent of policy choices. Our approach shares with these three papers an important limitation, namely, that the assumption that agents differ only in their initial stocks of capital coupled with an AK technology implies that there are no income dynamics.³ Finally, this paper shares a common feature with Viane and Zilcha (2003) in the sense that both relate the growth-inequality relationship to underlying structural characteristics, in a general equilibrium context, albeit a somewhat different one.

² See, among others, Aghion and Bolton (1997) and, as well as the overview in Aghion, Caroli, and García-Peñalosa (1999).

³ A more general study of heterogeneity and the dynamics of distribution in growth models can be found in Caselli and Ventura (2000).

The paper is organized as follows. Sections 2 and 3 present the structure of the model and derive the macroeconomic equilibrium. Section 4 examines the determinants of the distribution of income and Section 5 analyzes the relationship between growth and inequality in response to specified structural changes. Section 6 supplements our theoretical analysis with some numerical simulations. Section 7 concludes, while technical details are provided in the Appendix.

2. The model

2.1 Description of the decentralized economy

Technology and factor payments

Firms shall be indexed by j . We assume that the representative firm produces output in accordance with the production function

$$Y_j = F(L_j K, K_j) \tag{1a}$$

where K_j denotes the individual firm's capital stock, L_j denotes the individual firm's employment of labor, K is the average stock of capital in the economy, a proxy for the economy-wide stock of knowledge, so that $L_j K$ measures the efficiency units of labor employed by the firm. Production has the usual neoclassical properties of positive but diminishing marginal physical products and constant returns to scale in private capital, K_j , and in labor measured in efficiency units, $L_j K$. This means that the production function has constant returns to scale both in the accumulating factors, K_j and K , necessary for endogenous growth, and in the private factors K_j and L_j , necessary for marginal product factor pricing to be consistent with a competitive equilibrium.

All firms face identical production conditions. Hence they will all choose the same level of employment and capital stock. That is, $K_j = K$ and $L_j = L$ for all j , where L is the average economy-wide level of employment. The economy-wide capital stock yields an externality such that in equilibrium the aggregate (average) production function is linear in the aggregate capital stock, as in Romer (1986), namely⁴

⁴ We assume that the production function satisfies the Inada conditions $f(0) = 0, f'(0) \rightarrow \infty, f'(\infty) \rightarrow 0$

$$Y = F(LK, K) = f(L)K \quad f'(L) > 0, f''(L) < 0 \quad (1b)$$

We assume that the wage rate and the return to capital are determined by their respective marginal physical products. Differentiating the production function and given that firms are identical, we obtain

$$\left(\frac{\partial F}{\partial L_j} \right)_{K_j=K, L_j=L} = f'(L)K \equiv w(L)K \quad (2a)$$

$$\left(\frac{\partial F}{\partial K_j} \right)_{K=K, L=L} = f(L) - Lf'(L) \equiv r(L) \quad (2b)$$

implying that the equilibrium return to capital is independent of the stock of capital while the wage rate is proportional to the average stock of capital, and therefore grows with the economy.⁵ In addition, we have $\partial r / \partial L = -Lf''(L) > 0$ and $\partial w / \partial L = f''(L)K < 0$, reflecting the fact that more employment raises the productivity of capital but lowers that of labor.

Consumers

There is a mass 1 of infinitely-lived agents in the economy. Consumers are indexed by i and are identical in all respects except for their initial endowment of capital, K_{i0} . Since the economy is growing, we are interested in the share of individual i in the total stock of capital, k_i , defined as $k_i \equiv K_i / K$. Relative capital has a distribution function $G(k_i)$, mean $\sum_i k_i = 1$, and variance σ_k^2 .

All agents are endowed with a unit of time that can be allocated either to leisure, l_i or to work, $L_i = 1 - l_i$. A typical consumer maximizes expected lifetime utility, assumed to be a function of both consumption and the amount of leisure time, in accordance with the isoelastic utility function

$$\max \int_0^{\infty} \frac{1}{\gamma} (C_i(t) l_i^\eta)^\gamma e^{-\beta t} dt, \quad \text{with } -\infty < \gamma < 1, \eta > 0, 1 > \gamma(1 + \eta) \quad (3)$$

where $e \equiv 1/(1 - \gamma)$ equals the intertemporal elasticity of substitution.⁶ The overwhelming preponderance of empirical evidence suggests that this is relatively small, certainly well below unity,

⁵ Intuitively, in a growing economy, with the labor supply fixed, the higher income earned by labor is reflected in higher returns, whereas with capital growing at the same rate as output, returns to capital remain constant.

⁶ The parameter restrictions in (3) are introduced to ensure concavity of the utility function.

so that we shall assume $\gamma < 0$. The parameter η represents the elasticity of leisure in utility. This maximization is subject to the agent's capital accumulation constraint

$$\dot{K}_i = rK_i + (1-l_i)wK - C_i \quad (4)$$

With the equilibrium wage rate being tied to the aggregate capital stock, we observe from (4) that the individual's rate of capital accumulation depends on the aggregate stock of capital, which the individual takes as given. For expositional simplicity we abstract from the government.

2.2 Consumer optimization

The consumer's formal optimization problem is to choose her rate of consumption, leisure, and rate of capital accumulation to maximize (3) subject to the accumulation equation (4). The corresponding first-order conditions are

$$C_i^{\gamma-1} l_i^{\eta\gamma} = \lambda_i \quad (5a)$$

$$\eta C_i^{\gamma} l_i^{\eta\gamma-1} = wK \lambda_i \quad (5b)$$

$$r = \beta - \frac{\dot{\lambda}_i}{\lambda_i} \quad (5c)$$

where λ_i is agent i 's shadow value of capital, together with the transversality condition

$$\lim_{t \rightarrow \infty} \lambda_i K_i e^{-\beta t} = 0 \quad (5d)$$

These optimality conditions are standard. In equations (1) and (2) we have defined w , r , and f . There we have expressed them as functions of equilibrium employment, L , but assuming that the aggregate labor market clears, yields

$$\sum_j L_j = L = 1 - l = \sum_i (1 - l_i) \quad (6)$$

and we can equally well write them as functions of $(1-l)$, namely

$$w(l) \equiv f'(L) \equiv f'(1-l), \quad r(l) \equiv f(L) - Lf'(L) \equiv f(1-l) - (1-l)f'(1-l) \quad (7)$$

implying $(1-l)w(l) + r(l) = f(1-l) \equiv f(L)$.

2.3 Derivation of macroeconomic equilibrium

From the optimality conditions, together with the individual's accumulation equation, and the corresponding conditions for the aggregate economy, we shall derive the macroeconomic equilibrium, showing that the economy is in fact always on its balanced growth path. We begin by dividing (5b) by (5a) to obtain

$$\eta \frac{C_i}{K_i} = w(l) l_i \frac{K}{K_i} \quad (8)$$

while we may write the individual's accumulation equation (4) in the form

$$\begin{aligned} \psi_i &\equiv \frac{\dot{K}_i}{K_i} = r(l) + (1-l_i)w(l) \frac{K}{K_i} - \frac{C_i}{K_i} \\ &= r(l) + w(l) \frac{K}{K_i} \left((1-l_i) - \frac{l_i}{\eta} \right) \end{aligned} \quad (9)$$

Taking the time derivative of (5a) and combining with (5c) implies

$$(\gamma - 1) \frac{\dot{C}_i}{C_i} + \eta \gamma \frac{\dot{l}_i}{l_i} = \frac{\dot{\lambda}_i}{\lambda_i} = \beta - r(l) \quad \text{for each } i \quad (10)$$

The important point about (10) is that each agent, irrespective of her capital endowment, chooses the same growth rate for her shadow value of capital. Taking the time derivative of (8) implies

$$\frac{\dot{C}_i}{C_i} - \frac{\dot{l}_i}{l_i} = \frac{w'(l)l}{w(l)} \frac{\dot{l}}{l} + \frac{\dot{K}}{K} \quad (11)$$

Now consider equations (10) and (11) for individuals i and k . We obtain

$$\begin{aligned} (\gamma - 1) \left(\frac{\dot{C}_i}{C_i} - \frac{\dot{C}_k}{C_k} \right) + \eta \gamma \left(\frac{\dot{l}_i}{l_i} - \frac{\dot{l}_k}{l_k} \right) &= 0 \\ \left(\frac{\dot{C}_i}{C_i} - \frac{\dot{C}_k}{C_k} \right) - \left(\frac{\dot{l}_i}{l_i} - \frac{\dot{l}_k}{l_k} \right) &= 0 \end{aligned}$$

from which we infer

$$\frac{\dot{C}_i}{C_i} = \frac{\dot{C}_k}{C_k}; \quad \frac{\dot{l}_i}{l_i} = \frac{\dot{l}_k}{l_k} \quad \text{for all } i, k \quad (12)$$

That is, all agents will choose the same growth rate for consumption and leisure.

Now turn to the aggregates. Summing (8) over all agents and noting that $\sum_i k_i = 1$, $\sum_i l_i = l$, the aggregate economy-wide consumption-capital ratio is

$$\eta \frac{C}{K} = w(l)l \quad (8')$$

while summing over (9) yields the aggregate accumulation equation

$$\begin{aligned} \psi \equiv \frac{\dot{K}}{K} &= r(l) + (1-l)w(l) - \frac{C}{K} \\ &= r(l) + w(l) \left((1-l) - \frac{l}{\eta} \right) \end{aligned} \quad (9')$$

In addition, (12) implies that average consumption, C , and leisure, l , also grow at their respective common growth rates, namely

$$\frac{\dot{C}_i}{C_i} = \frac{\dot{C}}{C}; \quad \frac{\dot{l}_i}{l_i} = \frac{\dot{l}}{l} \quad \text{for all } i \quad (12')$$

The remainder of our derivation is to show that in equilibrium $l(t)$, $l_i(t)$, $k_i(t) \equiv K_i(t)/K(t)$ are constant through time, so that the economy is in fact always on its balanced growth path, just as it is with identical agents; see Turnovsky (2000). To show this, substitute (9'), (11), and (12) into (10) expressing it by the following differential equation in l :

$$\frac{dl(t)}{dt} = \frac{G(l)}{H(l)} \quad (13)$$

where $H(l) \equiv \left[\frac{1-\gamma(1+\eta)}{1-\gamma} \right] l - \frac{f''(1-l)}{f'(1-l)} > 0$

$$G(l) \equiv \frac{f(1-l) - (1-l)f'(1-l) - \beta}{1-\gamma} - f(1-l) + \frac{f'(1-l)l}{\eta}$$

Because time is bounded, in steady-state equilibrium $\dot{l} = 0$, with the corresponding stationary level of l being determined where $G(\bar{l}) = 0$. Thus the linearized dynamics of l about that point are represented by

$$\frac{dl(t)}{dt} = \frac{G'(\bar{l})}{F(\bar{l})}(l(t) - \bar{l}) \quad (14)$$

In the Appendix we show that under the conditions we have imposed, $G'(\bar{l}) > 0$, in which case (14) is an unstable differential equation. The only solution consistent with the eventual attainment of steady state is for $l(t)$ to be constant at all points of time.⁷ It then follows from (12') that $l_i(t)$ is also constant over time.

The next step is to combine (9) and (9') to obtain the following differential equation in the relative capital stock, $k_i(t) \equiv K_i(t)/K(t)$, namely

$$\dot{k}_i(t) = w(l) \left[\left(1 - l_i - \frac{l_i}{\eta} \right) - \left(1 - l - \frac{l}{\eta} \right) k_i(t) \right] \quad (15)$$

This equation describes the potential evolution of the relative wealth (capital), starting from the initial endowment k_0 . With l_i, l both constants this is a simple linear equation, the properties of which will depend the coefficient of $k_i(t)$, which we can determine from the transversality condition. If (5d) holds for all individuals it implies the aggregate condition

$$\lim_{t \rightarrow \infty} \lambda K e^{-\beta t} = 0 \quad (5d')$$

With l constant, (9') and (10) imply that λ and K both grow at constant rates. It is then straightforward to show that (5d') will be met if and only if

$$r > \psi \quad (16)$$

i.e. the equilibrium rate of return on capital must exceed the equilibrium growth rate. It then follows from the two equations in (9') that the transversality condition can be further written in the following

⁷ For more general production structures, particular involving two-sector economies, it is possible that (14) is unstable, giving rise to potential problems of indeterminate equilibria.

two equivalent ways⁸

$$\frac{C}{K} > w(1-l) \quad (17a)$$

$$l > \frac{\eta}{1+\eta}. \quad (17b)$$

The first equation asserts that part of the agent's capital income is consumed, while the latter imposes the restriction on leisure that ensures that this will be the case.

Now returning to (15) we see from (17b) that the coefficient of k_i is positive implying that the only solution consistent with long-run stability and the transversality condition is that the right hand side of (15) be zero, so that $\dot{k}_i = 0$ for all time. Since k_i reflects capital stocks that evolve gradually over time, this is accomplished by agents selecting their respective leisure, l_i , in accordance with the “relative labor supply” function

$$l_i - l = \left(l - \frac{\eta}{1+\eta} \right) (k_i - 1) \quad (18)$$

Thus the transversality condition (17b) yields a positive relationship between relative wealth and leisure, such that the relative wealth position of agents, k_i , is unchanging over time. The capital stock of all agents grows at the same rate, implying that at any point in time, the share of agent i , k_i , remains equal to her initial share $k_{i,0}$, say. Moreover, it follows from (10), (11), and (12) that individual and aggregate consumption also grow at the same common rate:

$$\frac{\dot{C}_i}{C_i} = \frac{\dot{C}}{C} = \frac{\dot{K}_i}{K_i} = \frac{\dot{K}}{K} \equiv \psi = \frac{r(l) - \beta}{1 - \gamma} \quad (19)$$

The relationship (18) is the crucial mechanism whereby the agent's initial relative endowment of capital impacts on the distribution of income. Wealthier agents have a lower marginal utility of wealth. They therefore choose to supply less labor and to “buy” more leisure. In effect, they compensate for their larger capital endowment, and the higher growth rate it would support, by providing less labor, thereby having an exactly offsetting effect on the growth rate,

⁸In the absence of labor income, this latter condition reduces to the well known condition $C/K > 0$.

which is therefore independent of the distribution of capital.

The role that the elasticity of labor supply is playing in the determination of income distribution is analogous to that it plays in other similar growth models. For example, government consumption expenditure will have capital accumulation effects in the Ramsey model, and growth effects in the Romer model if and only if labor is supplied elastically. In both cases it is the wealth effect and its impact on labor supply that is driving the underlying responses.

3. Macroeconomic equilibrium

The above argument implies that the economy is always on its balanced growth path, the key equilibrium relationships of which can be summarized by

Equilibrium growth rate

$$\psi = \frac{r - \beta}{1 - \gamma} \quad (20a)$$

Individual consumption-capital ratio

$$\frac{C_i}{K_i} = \frac{w}{\eta} \frac{l_i}{k_i} \quad (20b)$$

Aggregate consumption-capital ratio

$$\frac{C}{K} = \frac{w}{\eta} l \quad (20c)$$

Individual Budget Constraint

$$\psi = r + w \frac{1 - l_i}{k_i} - \frac{C_i}{K_i} \quad (20d)$$

Goods market equilibrium

$$\psi = f(L) - \frac{C}{K} \quad (20e)$$

Recalling the definitions of $r(l)$, $w(l)$, and $\Omega(l)$, and given k_i , these equations jointly

determine the individual and aggregate consumption-capital ratios, C_i/K_i , C/K , the individual and aggregate leisure times, l_i , l , and the average (common) growth rate, ψ .

Using (20a), (20c), and (20e), the macroeconomic equilibrium of the economy can be summarized by the following pair of equations that jointly determine the equilibrium mean growth rate, ψ , and average leisure time, l :

$$\mathbf{RR} \quad \psi = \frac{f(1-l) - (1-l)f'(1-l) - \beta}{1-\gamma}, \quad (21a)$$

$$\mathbf{PP} \quad \psi = f(1-l) - \frac{lf'(1-l)}{\eta}. \quad (21b)$$

The first equation describes the relationship between ψ and l that ensures the equality between the risk-adjusted rate of return to capital and return to consumption. The second describes the combinations of the mean growth and leisure that ensure product market equilibrium holds. We shall focus our attention on solutions that are not only viable, in the sense of satisfying the transversality condition, but also generate positive equilibrium growth. From (21b) and (17b), the equilibrium solution for l must lie within the range:

$$\frac{\eta}{s_w + \eta} > l > \frac{\eta}{1 + \eta} \quad (22)$$

where $s_w \equiv f'(L)L/f(L)$ is the share of output accruing to labor. For the Cobb-Douglas production function, s_w is just constant.

These RR and PP locuses are depicted in Figure 1, and their formal properties are discussed in the Appendix. First, note that equation PP is always decreasing in l , reflecting the fact that more leisure time reduces output, thus increasing the consumption-output ratio and having an adverse effect on the growth rate of capital. In addition, the RR curve is also decreasing in l . Intuitively, a higher fraction of time devoted to leisure reduces the productivity of capital, requiring a fall in the return to consumption. This is obtained if the growth of the marginal utility of consumption rises, that is, if the balanced growth rate falls. Under weak conditions, both schedules are concave, and sufficient conditions for a unique equilibrium exists to exist are

$$-\gamma f(1) + f'(1) + \beta > 0, \quad (23)$$

together with the stability condition, $G'(l) > 0$, both of which are certainly met if $\gamma \leq 0$, and hold under much weaker conditions as well.

4. The distribution of income and welfare

We now consider the relative income of an individual having capital stock K_i . Her gross income is simply $Y_i = rK_i + wK(1-l_i)$, while average economy-wide income is $Y = rK + wK(1-l)$. Using equation (18) to substitute for the individual's labor supply, we can write the relative income of individual i , $y_i \equiv Y_i/Y$, as

$$y_i(l, k_i) = k_i + \frac{w}{(1+\eta)f} (1-k_i) = k_i + \frac{f'(1-l)}{(1+\eta)f(1-l)} (1-k_i) \quad (24)$$

which we may express more compactly as:

$$y_i(l, k_i) - 1 = \rho(l, \eta)(k_i - 1), \quad \text{where } \rho(l) \equiv 1 - \frac{f'(1-l)}{(1+\eta)f(1-l)}, \quad (24')$$

Equation (24') emphasizes that the distribution of income depends upon *two* factors, the initial (unchanging) distribution of capital, and the equilibrium allocation of time between labor and leisure, insofar as this determines factor rewards. The net effect of an increase in initial wealth on the relative income of agent i is given by $\rho(l)$. As long as the equilibrium is one of positive growth, it is straightforward to show that⁹

$$0 < \rho(l, \eta) < 1 \quad (25)$$

Thus relative income is strictly increasing in k_i , indicating that although richer individuals choose a lower supply of labor, this effect is insufficiently strong to offset the impact of their higher capital income. Consequently, the standard deviation of income across the agents, σ_y , which provides a

⁹Writing $\rho(l, \eta) = (1/f) \left[(f - (lf'/\eta)) + (f'/\eta)(l - (\eta/(1+\eta))) \right]$, if the equilibrium is one of positive growth, (21b) implies that the first term in brackets is positive, while the transversality condition (17b) implies that the second term is positive, thus ensuring that $\rho(l, \eta) > 0$. The fact that $\rho(l, \eta) < 1$ is immediate from its definition.

convenient measure of income inequality, is less than their (unchanging) variability of capital, σ_k . To see this more intuitively, note that the relative labor supply function, equation (18), implies that the standard deviation of labor supplies, $\sigma_L = \sigma_l$, can be expressed as

$$\sigma_l = \left(l - \frac{\eta}{1 + \eta} \right) \sigma_k. \quad (18')$$

From (22) the term in brackets in (18') lies between 0 and 1, indicating that labor supplies are less unequally distributed than are capital endowments, thus reducing the variability of income relative to that of capital.

The second point to note is that we can rank different outcomes according to inequality without needing any information about the underlying distribution of capital. For a given distribution of capital, structural or policy changes affect the distribution of income solely through their impact on relative prices, as captured by $\rho(l)$. Correia (1999) has shown that when agents differ only in their endowment of one good, there exists an ordering of outcomes by income inequality, as measured by second-order stochastic dominance.¹⁰ That ordering is determined by equilibrium prices, and is independent of the distribution of endowments.

The DD locus in the lower panel of Fig. 1 illustrates the relationship between the standard deviation of relative income, σ_y , our measure of income inequality, and the standard deviation of capital endowments, σ_k , namely

$$\mathbf{DD} \quad \sigma_y = \rho(l, \eta) \sigma_k \quad (21c)$$

Given the standard deviation of capital, σ_k , the standard deviation of income is a decreasing and concave function of aggregate leisure time. This is because as leisure increases (and labor supply declines) the wage rate rises and the return to capital falls, compressing the range of income flows between the wealthy with large endowments of capital and the less well endowed. Thus, having determined the equilibrium allocation of labor from the upper panels in Fig. 1, (21c) determines the corresponding unique variability of income across agents. We may summarize the properties of

¹⁰ Her results also require that the economy be amenable to Gorman aggregation, which is the case in our setup.

equilibrium income distribution in the following proposition:

Proposition 1:

- (i) The degree of income inequality is less than the degree of wealth inequality.
- (ii) The ratio of an agent's deviation in income from its mean, $y_i - 1$, to her corresponding deviation in capital, $k_i - 1$, is identical across all agents. Furthermore, in a growing economy, agents having an above average endowment of capital have an above average level of income and vice versa.
- (iii) Given the initial distribution of capital across agents, structural changes and policy responses influence the distribution of income through their effect on labor supply. However, changes in the structural parameter, η , have an additional direct distributional effect.

Proposition 1 highlights the central role played by the labor supply in determining the distribution of income. In fact from equation (24) we can see that inequality depends, on the one hand, on the labor share which determines the relative rewards of capital and labor, and on the other, on the elasticity of the labor supply which determines the dispersion of individual labor supplies. A policy maker could then eliminate all income dispersion by setting $f' = (1 + \eta)f$ in (24'), thus driving the wage share to $s_w = (1 + \eta)(1 - l)$. However, this is associated with a negative equilibrium growth rate.¹¹

5. The relationship between inequality and growth

As emphasized at the outset, and as our analysis has illustrated, inequality and growth are jointly determined. We now use Fig 1 to explore the relationship in response to two structural shocks: (i) an increase in savings, generated by a reduction in the rate of time discount, β , and (ii)

¹¹This can be easily shown by substituting $f' = (1 + \eta)f$ into (21b) and recalling the transversality condition. Note that the transversality condition ensures $s_w < 1$, so that eliminating all income dispersion is indeed feasible. See García-Peñalosa and Turnovsky (2004) for an analysis of the policy implications of this model.

an increase in productivity.

5.1 Decrease in rate of time preference, β

This is illustrated in Fig. 2. The intersection of the PP and RR curves at Q determines the initial equilibrium fraction of time devoted to leisure, \bar{l} , and the corresponding growth rate, $\bar{\psi}$. Given \bar{l} , the corresponding point M on the DD curves determines the corresponding degree of income inequality, $\bar{\sigma}_y$. A decrease in β shifts the RR curve upward, to R'R', with PP and DD remaining unchanged. As a result, the new equilibrium shifts to Q' and M', with a higher growth rate, less leisure, and a greater income inequality.

The intuition for this response is straightforward. Given labor supply, the decline in impatience associated with the lower rate of time preference leads to an increase in savings and an immediate increase in the growth rate. This is represented by the move from Q to S on R'R. But the higher growth rate implies higher future wages, and hence higher consumption for any extra time spent at work. It therefore reduces leisure, increasing the supply of labor, raising the return to capital and causing a further increase in the growth rate, as measured by the move SQ' along the R'R curve. The reallocation of time in turn, affects the distribution of income. The increase in labor supply raises the return to capital and decreases that to labor. Since labor is more equally distributed than capital, the income gap between any two individuals rises and income inequality increases.

5.2 Increase in productivity

We assume that level of productivity is represented by a shift parameter, A , in the production function, so that the aggregate production function is now represented by $Y = Af(L)K$. From Fig. 3 we see that an increase in A leads to an upward shift in both the RR and PP curves, the latter rotating about the point T, with the equilibrium shifting from Q and M, to Q' and M', respectively. The upward shift in the RR curve has the effects described above, and the same intuition applies. However, the upward shift in the PP curve (for $\psi > 0$) has offsetting effects, causing an increase in l accompanied by a lower growth rate, ψ . On impact, given labor supply and output, this raises the growth rate and the return on consumption, causing agents to increase consumption and leisure over

work. This causes a reduction in output and the growth rate, leading to a reduction to the return to capital and consumption. On balance the former effect can be shown to dominate and the new equilibrium at Q' is associated with a higher growth rate and less leisure, and therefore greater income inequality.¹²

We may therefore summarize these results with the following:

Proposition 2:

A decrease in the rate of time preference, or an increase in productivity, induces a *positive* relationship between growth and income inequality.

Two points should be noted. First, the elasticity of labor supply is critical to these relationships. If labor were inelastically supplied at $l = 1$, say, the relative income of agent i would be $y_i = (w + rk_i)/(w + r)$. In this case the AK technology results in a constant wage and interest rate, so that this expression would be unaffected by these structural changes. In our setup they matter because they affect the growth rate, and this, in turn, impacts labor supply and factor rewards.

Second, it is evident from Figure 1 that with both RR and PP being negatively sloped, any structural or policy change that induces a shift in only *one* of these curves always generates a negative relationship between growth and leisure. If further, the DD curve remains unchanged, this translates into a positive relationship between growth and income inequality. The decrease in β is one example of this and a change in γ is another.

6. Numerical examples

To obtain further insights into the growth-income inequality relationship we provide some numerical examples. To do so, we employ the aggregate equilibrium Cobb-Douglas production function, $Y = AL^\alpha K$, and use the following, mostly conventional, parameter values:

¹² This can be easily established by taking the differentials of the equilibrium relationships (22a) –(22c), the details of which are omitted.

Parameter Values

Production	$A = 0.60, \alpha = 0.60$
Preferences	$\beta = 0.04, \gamma = -2, \eta = 1.75$

The choice of production elasticity of labor measured in efficiency units implies that 60% of output accrues to labor. The rate of time preference of 4% is commonly used in calibrations for the US economy, while the choice of the elasticity on leisure, $\eta = 1.75$, is standard in the real business cycle literature, implying that about 72% of time is devoted to leisure, consistent with empirical evidence. Estimates of the intertemporal elasticity of substitution (IES) are more variable throughout the literature. With few exceptions they lie in the range (0,1). Our choice of 1/3 is in line with early estimates based on consumption. However, more recent empirical evidence, based on stock market data, suggests that it is substantially higher, perhaps 2/3 or even higher,¹³ and alternative values will be used. The choice of the scale parameter $A = 0.60$, is set to yield a plausible value for the equilibrium capital-output ratio.

Our numerical measures of inequality are the standard deviation of income employed in our theoretical discussion, as well as the more standard Gini coefficient. This involves choosing an initial distribution of wealth, which is less straightforward, as data on the distribution of wealth are difficult to obtain.¹⁴ The choice we have made yields a Gini coefficient of almost 33%, which compares with 37.8% and 32.52% for the US and Sweden in 1990, respectively.¹⁵

The first line of Table 1 reports the benchmark equilibrium for our base parameters. It indicates that 72.7% of time is allocated to leisure, yielding a growth rate of 2.3%. The standard deviation of income inequality is 0.199 times the standard deviation of the distribution of wealth, and the Gini coefficient is 32.88, as noted. This is a plausible benchmark and $l=0.727$ lies in the

¹³ See, for example, Attanasio, Banks, and Tanner (2002), Vissing-Jorgensen (2002), and the discussion in Guvenen, (2003).

¹⁴ We have assumed that the distribution of wealth among the 5 quintiles is 0, 0, 1.2%, 12%, 86.8%, which are consistent with the data. For example, in the US in 1992 the bottom 40% of the population held 0.4% of total wealth, while the top 20% owed 83.8% of the total; see Wolff (1998). Since we have no heterogeneity in wages, we also suppose that the bottom quintile has no labor income.

¹⁵ These and all subsequent data on income inequality are from Brandolini (2003).

range [0.636, 0.745], consistent with the constraints in (22).

The next four lines in Table 1 report, sequentially, the effect of a 50 per cent increase in the main parameters of the model: the level of technology, the intertemporal elasticity of substitution, the rate of time preference, and the elasticity of labor. These exercises show that the predictions of the model are roughly in line with a number of stylized facts concerning income inequality in OECD countries. Furthermore, the size of the effects reported can, in some cases, explain a substantial fraction of cross-country disparities.

6.1 Increase in productivity

Consider first an increase in A of 50%, from 0.6 to 0.9. Assuming a 2% annual rate of productivity growth, such an increase in A approximates the accumulated increase in productivity over a 20 year period. We see that it enhances the growth rate by 1.877 points, raising the Gini coefficient by 0.64 points. This mechanism could partly explain the recent increase in income inequality in the US. Between 1975 and 1995 the Gini coefficient in the US increased by 6.4 Gini points. The period also witnessed the widespread adoption of IT technologies. It has been argued that the resulting productivity increase led to greater wage inequality, and hence greater income inequality.¹⁶ Our analysis implies that an increase in the technology parameter would also impact the distribution of income through its effect on the returns to capital and labor. This effect is significant, accounting for 10 per cent of the overall change during these two decades.

6.2 Increase in intertemporal elasticity of substitution

The data on inequality consistently show that incomes are more unequally distributed in the US than in other OECD countries. For example, in 1984, the Gini coefficient in the US was 36.90, while those of France, Italy, and Germany were 34.91, 33.15, and 32.20, respectively.¹⁷ That is, inequality in these countries was between 2 and 4.6 Gini points lower than in the US. One possible explanation for the high degree of inequality observed in the US is a larger intertemporal elasticity of

¹⁶ See Aghion, Caroli, and García-Peñalosa (1999).

¹⁷ This is the most recent year for which comparable data for these countries and Japan is available.

substitution (IES). As noted by Guvenen (2003), empirical microeconomic studies suggests that the IES increases with wealth, and with stock-ownership being more widespread in the US, one can reasonably conclude that the IES is correspondingly larger than in many OECD countries. The third row in Table 1 shows that an increase in the IES from $1/3$ to $1/2$ results in a 1.7 point increase in inequality. Indeed, a modest difference in the IES thus accounts for a substantial fraction of the difference in income inequality.

But even within the US, it is widely agreed that wealth holdings have increased over time, suggesting that the IES has increased over time as well. From this standpoint, row 3 in Table 1 suggests that a modest increase in the IES over time can account for a significant fraction of the increase in income inequality that has been occurring in the US during recent years.

6.3 Increase in preference for leisure

An alternative reason for the observed disparities between the US and Europe may be a difference in the preference for leisure. Annual working hours are substantially lower in most European countries than in the US. For example, in 2002, American workers spent 1,815 hours at work, while those in France and Germany worked for under just 1,500 hours (OECD, 2004). A possible cause of this difference is that Europeans have a greater desire for leisure. Our third exercise consists in increasing η by 50%, from 1.75 to 2.625. The effect is to increase dramatically the fraction of time devoted to leisure, from 0.727 to 0.802 (i.e. a 27% reduction in working time). Our model suggests that this difference in preferences leads to a growth rate that is about 0.6 percentage points lower, and a Gini coefficient almost 2.2 points smaller. This indicates that differences in the elasticity of labor supply could account for a large fraction of the observed 2 to 5 point difference in Gini coefficients between the US and continental Europe.

6.4 Decrease in rate of time preference

Finally, we consider a comparable (percentage-wise) decrease in the rate of time preference. A reduction of 50% has a relatively smaller effect on the growth rate and relatively larger effect on inequality, raising the Gini coefficient by almost 1 point. This may help account for the rather high

inequality observed in Japan (Gini coefficient of 35.41 in 1984), a country with a high savings rate, which is often argued to be the result of a lower rate of time preference.

Table 1 also sheds light on the varied empirical evidence on the relationship between inequality and growth. In the table, we have reported $d\rho/d\psi$. This is always positive indicating the positive relationship between growth and inequality. Note, however, the sharp differences in the slopes of the tradeoffs. A productivity increase has a relatively smaller effect on inequality, for a given increase in the growth rate, whereas the preference in leisure has the greatest effect, about 10 times as much. The slopes $d\rho/d\psi$ for a change in β and a change in the IES are approximately the same.¹⁸ We can think of A as a productivity parameter that varies over time within the same country, while the preference parameters are viewed as constant over time for a particular economy. These results then can explain why fixed-effects estimations of the relationship between inequality and growth, which only estimate changes over time within a country, find a much weaker correlation between these two variables than do studies in which the cross-country correlation is examined (see Forbes, 2000, and Barro, 2000, respectively).

7. Concluding comments

The relationship between growth and inequality remains largely unresolved, despite the intensive research devoted to it over the past 50 years. Empirical evidence is inconclusive, some authors finding these two variables to be negatively related, while others obtain a positive relationship; see Lundberg and Squire (2003). Indeed, the ambiguity of the empirical findings should not be too surprising when one considers that both variables are endogenous, so that their co-movements are likely to depend upon the underlying structural and policy changes driving them. To study this requires that they be analyzed within the context of a consistently specified growth model. This is important, not only to understand the relationship between them, but also in devising appropriate policy responses.

In this paper we have developed a small canonical model, extending the basic AK growth

¹⁸ From the equilibrium conditions (20), for infinitesimal changes we can formally establish the relationships: $0 < (d\rho/d\psi)_{dA} < (d\rho/d\psi)_{d\beta} = (d\rho/d\psi)_{d\gamma}$.

model with endogenous labor supply to agents having heterogeneous initial endowments of capital. The key mechanism whereby this initial distribution of capital endowments influences the distribution of income is through their differential wealth effects, and their impact on labor supply. If capital endowments are more unequally distributed than labor endowments, any structural change that tends to increase the supply of labor and raise the relative return to capital, raises the return of the factor that is the source of the inequality, and the distribution of income becomes more unequal. This will tend to induce a positive relationship between inequality and growth. Indeed our model tends to support such a positive relationship in the sense that it almost always emerges in the case of independent structural changes.

Our results contrast with the literature that has found that greater inequality results in slower growth. It is important to emphasize the two crucial differences between previous work and our approach. First, earlier work has focused on the effect of *wealth* inequality on growth. In contrast, we have chosen a framework in which the distribution of wealth has no impact on growth, and examined the determinants of the distribution of income. This means that the two mechanisms are not mutually exclusive, and could well be in operation simultaneously. Second, we have emphasized the simultaneous determination of growth and personal incomes, rather than the effect of initial wealth on subsequent growth. This difference can explain why earlier empirical work which regressed long-run growth rates on initial income inequality (a proxy for wealth inequality) found a negative impact, while more recent studies which considered the short-term effect obtained a positive correlation.

Finally, we conclude with a caveat. While the simple AK model has the advantage of providing a tractable framework for investigating the growth-inequality relationship and its policy implications, it also has the limitation that the economy is always on its balanced growth path. It therefore cannot address issues pertaining to the dynamics of wealth and income distribution. This is an important subject for further work. The analysis of this paper suggests that applying the present approach to the Ramsey model with its transitional dynamics, is not only important in its own right, but may also provide a tractable framework for investigating this aspect.

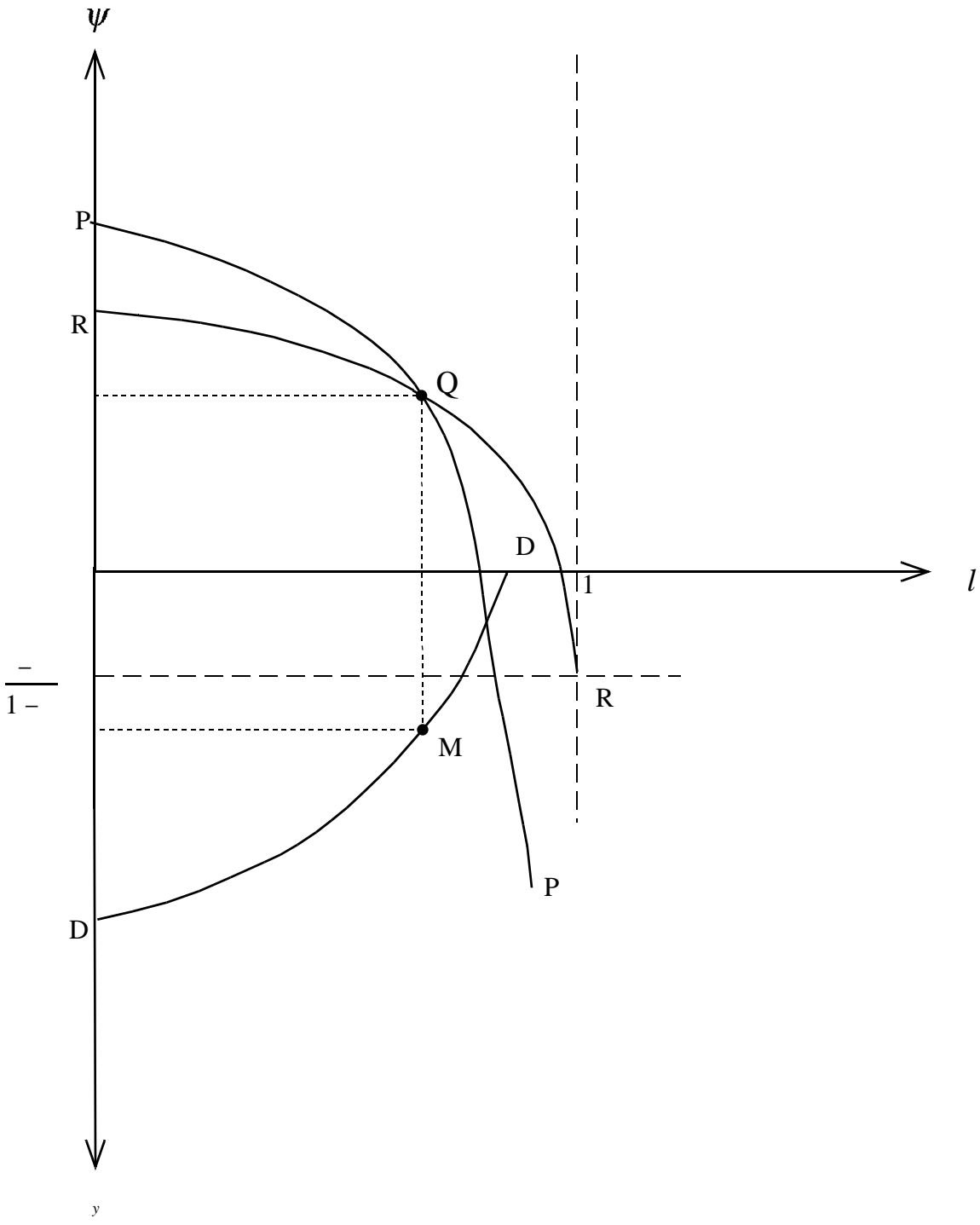

Fig 1: Equilibrium Growth, Employment, and Income Distribution

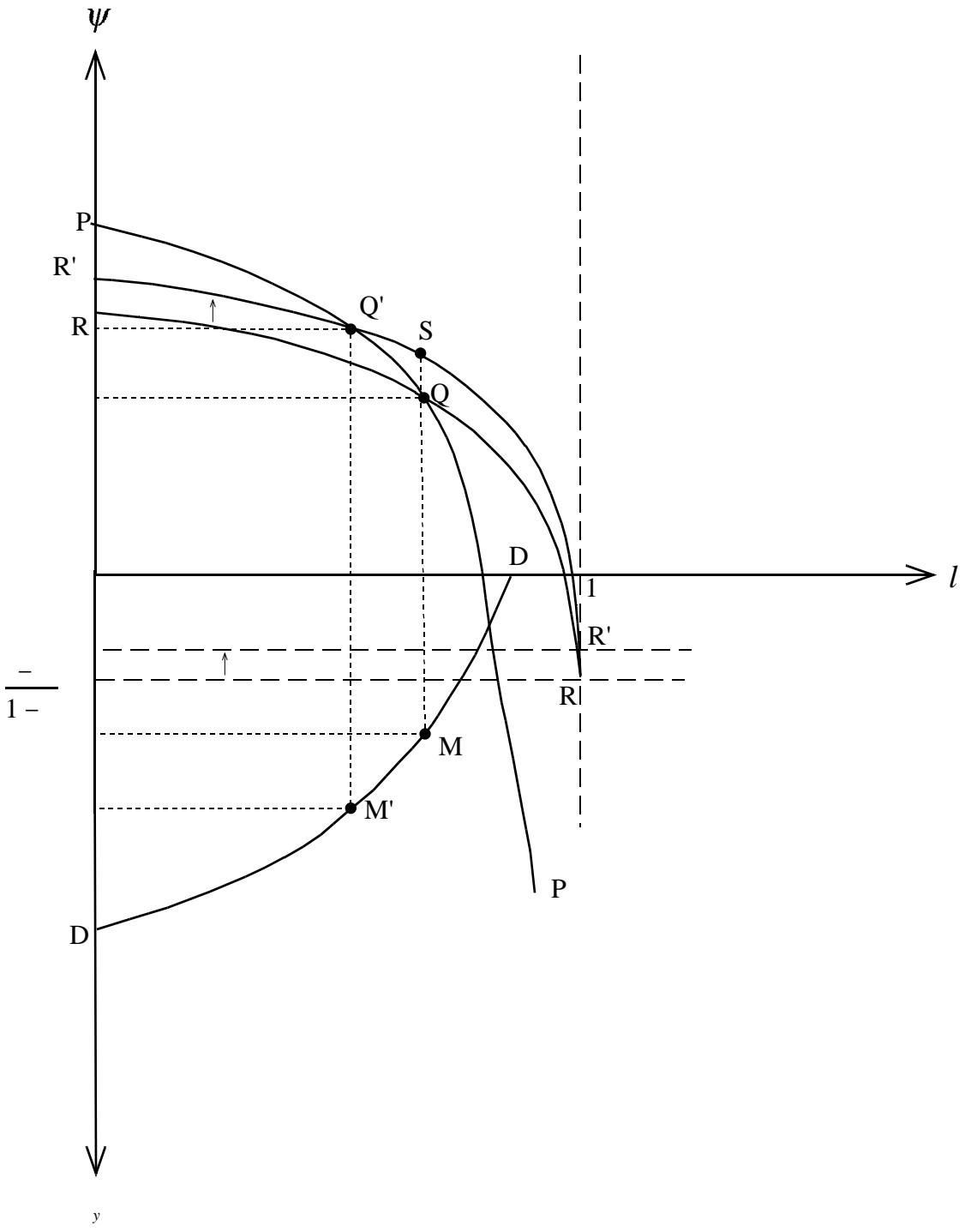

Fig 2: Decrease in Rate of Time Preference

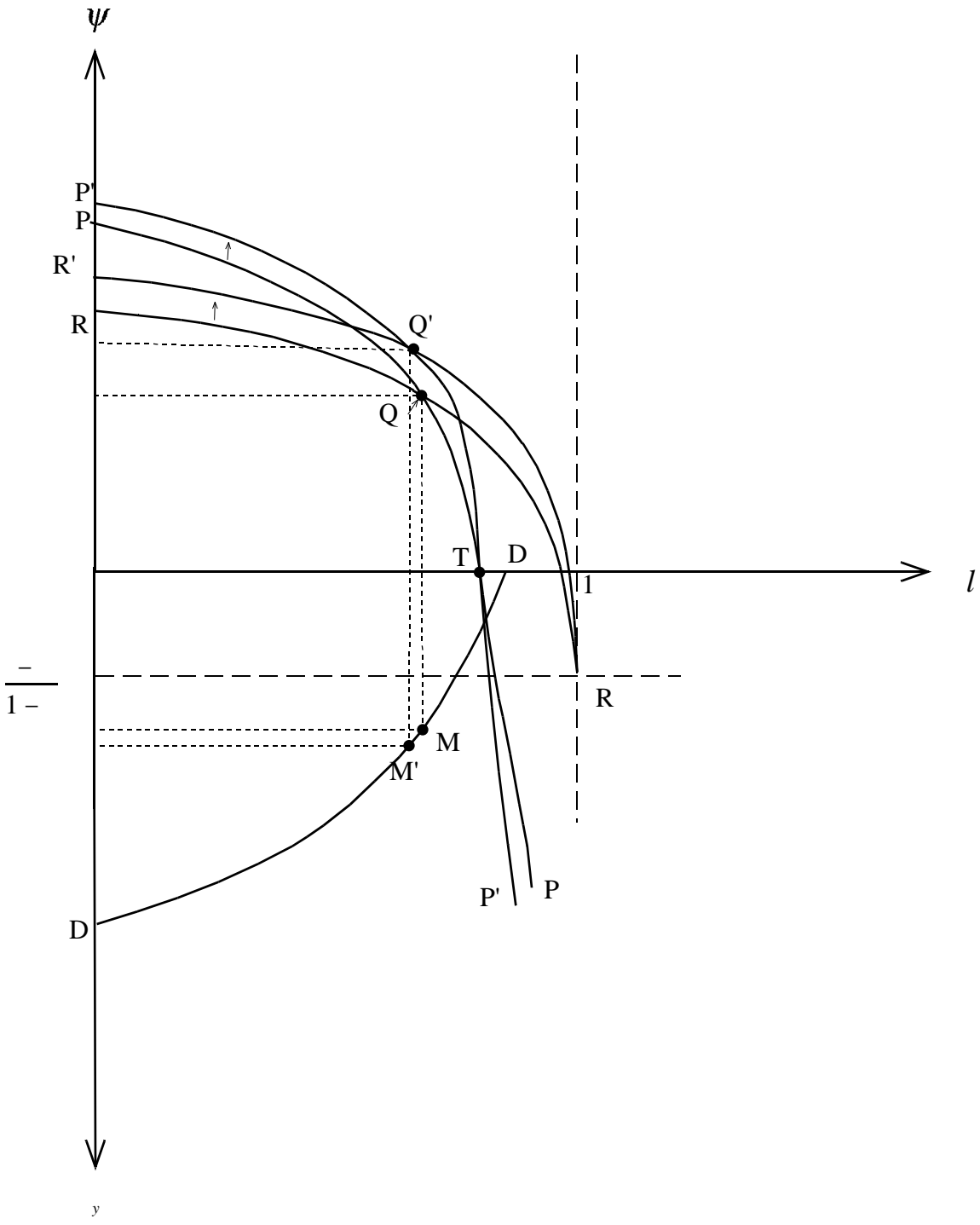

Fig 3: Increase in Productivity

Table 1
Growth and the Distribution of Income

	l	ψ %	ρ %	$Gini(y)$	$d\psi$	$d\rho$	$d\rho/d\psi$	$dGini$
Benchmark	0.727	2.334	19.946	32.88	--	--	--	--
50% increase in A from 0.60 to 0.90	0.724	4.211	20.990	33.52	1.877	1.044	0.556	0.64
50% increase in IES from 1/3 to 1/2 (γ from -2 to -1)	0.718	3.620	22.743	34.59	1.286	2.797	2.175	1.71
50% increase in η from 1.75 to 2.625	0.802	1.695	16.439	30.71	-0.639	-3.507	5.488	-2.17
50% decrease in β from 0.04 to 0.02	0.722	3.044	21.506	33.84	0.710	1.560	2.197	0.96

Appendix

A.1 Conditions for $G'(l) > 0$

Taking the derivative of $G(l)$ yields

$$G'(l) = \frac{(1-l)f''(L)}{1-\gamma} + f'(L) \left(1 + \frac{1}{\eta}\right) - f''(L) \frac{l}{\eta} \quad (\text{A.1})$$

Now for a production function of the form (1a), the elasticity of substitution, σ , can be expressed as

$$\sigma \equiv \frac{F_1 F_2}{F F_{12}} = \frac{-f'(L)[f(L) - Lf'(L)]}{f(L)f''(L)L} \quad (\text{A.2})$$

so that

$$f'' = \frac{-f'[f - Lf']}{fL\sigma} \quad (\text{A.3})$$

We define labor's share of output by

$$s_w \equiv \frac{Lf'(L)}{f(L)} \quad (\text{A.4})$$

Substituting (A.3) and (A.4) into (A.1), yields

$$\text{sgn}(G'(l)) = \text{sgn} \left(-\frac{1}{1-\gamma} + \frac{(1+1/\eta)}{1-s_w} \sigma + \frac{l}{(1-l)\eta} \right) \quad (\text{A.5})$$

The transversality condition (17b) implies $l/(1-l) > \eta$, and given our restriction $\gamma < 0$, the right hand side of (A.5) is positive, establishing $G'(l) > 0$, as asserted.

A.2 Conditions for a balanced growth path

Differentiating the relations in (22a) and (22b), we obtain

$$\left. \frac{\partial \psi}{\partial l} \right|_{RR} = \frac{Lf''(L)}{1-\gamma} < 0, \quad \left. \frac{\partial \psi}{\partial l} \right|_{PP} = - \left(1 + \frac{1}{\eta} \right) f'(L) + \frac{1-L}{\eta} f''(L) < 0 \quad (\text{A.6a})$$

$$\left. \frac{\partial^2 \psi}{\partial l^2} \right|_{RR} = -\frac{f''(L) + Lf'''(L)}{(1-\gamma)} \quad \left. \frac{\partial^2 \psi}{\partial l^2} \right|_{PP} = \left(1 + \frac{2}{\eta}\right) f''(L) - \frac{1-L}{\eta} f'''(L) \quad (\text{A. 6b})$$

so that both the (PP) and (RR) have negative slopes. Also

$$\begin{aligned} \psi_{RR}(l=0) &= \frac{f(1) - f'(1) - \beta}{1-\gamma}, & \psi_{RR}(l=1) &= -\frac{\beta}{1-\gamma} \\ \psi_{PP}(l=0) &= f(1), & \psi_{PP}(l=1) &= -\infty. \end{aligned}$$

Under weak conditions (A.6b) can both be shown to be negative, so that both the RR and PP curves are concave. To establish these conditions, we shall focus on the case of a constant elasticity of substitution production function, in which σ is constant. Differentiating (A.3) with respect to L , we obtain

$$f''' = -f'' \frac{[f - 2Lf']}{\sigma fL} + \frac{f' [f^2 - 2L^2 f'^2]}{\sigma f^2 L^2}$$

Using (A.3) and (A.7a),

$$\left. \frac{\partial^2 \psi}{\partial l^2} \right|_{RR} = \frac{f'(f - Lf')}{\sigma fL(1-\gamma)} \left\{ 1 - \frac{f - 2Lf'}{\sigma f} - \frac{f + Lf'}{f} \right\}$$

and thus

$$\text{sgn} \left(\left. \frac{\partial^2 \psi}{\partial l^2} \right|_{RR} \right) = \text{sgn} \left\{ (s_w - 1) + s_w(1 - \sigma) \right\} \quad (\text{A.7a})$$

Similarly,

$$\left. \frac{\partial^2 \psi}{\partial l^2} \right|_{PP} = \frac{f'(f - Lf')}{\sigma fL(1-\gamma)} \left\{ -\left(1 + \frac{2}{\eta}\right) - \frac{1-L}{\eta} \frac{f - 2Lf'}{\sigma fL} - \frac{1-L}{\eta} \frac{f + Lf'}{fL} \right\}$$

and thus

$$\text{sgn} \left(\left. \frac{\partial^2 \psi}{\partial l^2} \right|_{PP} \right) = \text{sgn} \left\{ -\left(1 + \frac{2}{\eta}\right) \sigma - \frac{1-L}{\eta L} (1 - 2s_w) - \frac{1-L}{\eta L} (1 + s_w) \sigma \right\} \quad (\text{A.7b})$$

Both (A.7a) and (A.7b) will be negative under weak conditions. For example,

$$\sigma > \frac{2s_W - 1}{s_W} \quad (\text{A.8})$$

which is necessary and sufficient for (A.7a) to be negative, is also sufficient for (A.7b) to be negative as well. This clearly holds for the Cobb-Douglas production function, and assuming s_W to be around 0.6, it requires $\sigma > 0.33$, which is a weak condition.

Thus concavity can be reasonably assumed, and given concavity, sufficient condition to ensure the existence of a unique equilibrium are: (i) $\psi_{PP}(l=0) > \psi_{RR}(l=0)$, so that the (PP) schedule lies above the (RR) curve at $l=0$, and (ii) the (PP) schedule is steeper at each point than is the RR schedule.. In this case, the (PP) schedule lies below (RR) for $l=1$, and the two schedules only cross once. Condition (i) is satisfied when

$$-\gamma f(1) + f'(1) + \beta > 0, \quad (\text{A.9})$$

while condition (ii) will be met if and only if the stability condition $G'(l) > 0$ is met. Both of these are very weak conditions and will certainly hold if $\gamma < 0$, as we are assuming.

References

- Aghion, P, E. Caroli, and C. García-Peñalosa, 1999, "Inequality and Economic Growth: The Perspective of the New Growth Theories," *Journal of Economic Literature* 37, 1615-1660.
- Aghion, P. and P. Bolton. 1997. "A Trickle-Down Theory of Growth and Development with Debt Overhang," *Review of Economic Studies*, 64, 151-72.
- Alesina and Rodrik, 1994, "Distributive Politics and Economic Growth," *Quarterly Journal of Economics*, 109, 465-490.
- Algan, Y., A. Cheron, J-O Hairault, and F. Langot, 2003, "Wealth Effect on Labor Market Transitions," *Review of Economic Dynamics*, 6, 156-178.
- Anand, S. and R. Kanbur, 1993, "The Kuznets Process and the Inequality-Development Relationship," *Journal of Development Economics*, 40, 25-52.
- Atkinson, A.B., 2003, "Income Inequality in OECD Countries: Data and Explanations," *CESifo Economic Studies*, 49, 479-513.
- Attanasio, O.P., J. Banks, and S. Tanner, 2002, "Asset Holding and Consumption Volatility," *Journal of Political Economy*, 110, 771-93.
- Barro, R.J., 2000, "Inequality and Growth in a Panel of Countries," *Journal of Economic Growth*, 5, 5-32.
- Bénabou, R., 1996a, "Heterogeneity, Stratification, and Growth: Macroeconomic Implications of the Community Structure and School Finance," *American Economic Review*, 86, 584-609.
- Bénabou, R., 1996b, "Equity and Efficiency in Human Capital Investment: The Local Connection," *Review of Economic Studies*, 63, 237-264.
- Bertola, G., 1993, "Factor Shares and Savings in Endogenous Growth," *American Economic Review*, 83, 1184-98.
- Brandolini, A., 2003, "A Birds-eye View of Long-run Changes in Income Inequality," Bank of Italy, mimeo.
- Caselli, F. and J. Ventura, 2000, "A Representative Consumer Theory of Distribution," *American Economic Review*, 90, 909-926.

- Checchi, D. and C. García-Peñalosa, 2005, "Labour Shares and the Personal Distribution of Income in the OECD," mimeo, GREQAM.
- Cheng, I-H. and E. Rench, 2000, "The Effect of the Run-up in the Stock Market on Labor Supply," *Federal Reserve Bank of Chicago Economic Perspectives*, 24, 48-65.
- Coronado, J.L. and M. Perozek, 2003, "Wealth Effects and the Consumption of Leisure: Retirement Decisions During the Stock Market Boom of the 1990s," *Board of Governors of the Federal Reserve System, Finance and Economics Discussion Series*, 2003-20.
- Correia, I.H., 1999, "On the Efficiency and Equity Trade-off," *Journal of Monetary Economics*, 44, 581-603.
- Deininger, K. and Squire, L., 1996. "Measuring Income Inequality: a New Data Base," *The World Bank Economic Review* 10, 565-591.
- Forbes, K., 2000, "A Reassessment of the Relationship between Inequality and Growth," *American Economic Review*, 90, 869-887.
- Galor, O. and D. Tsiddon, 1997, "Technological progress, Mobility, and Economic Growth," *American Economic Review*, 87, 363-382.
- Galor, O. and J. Zeira, 1993, "Income Distribution and Macroeconomics," *Review of Economic Studies*, 60, 35-52.
- García-Peñalosa, C. and S.J. Turnovsky, 2004, "Growth, Inequality, and Fiscal Policy with Endogenous Labor Supply: What are the Relevant Tradeoffs?" mimeo.
- Guvenen, F., 2003, "Reconciling Conflicting Evidence on the Elasticity of Intertemporal Substitution: A Macroeconomic Perspective", mimeo University of Rochester.
- Gylfason, T. and G. Zoega, 2003, "Inequality and Growth: Do Natural Resources Matter?" in *Inequality and Growth: Theory and Policy Implications*: T.S. Eicher and S.J. Turnovsky (eds.), Cambridge MA: MIT Press.
- Holtz-Eakin, D., D. Joulfaian, and H.S. Rosen, 1993, "The Carnegie Conjecture: Some Empirical Evidence," *Quarterly Journal of Economics*, 108, 413-435.
- Kuznets, S., 1955, "Economic Growth and Income Inequality," *American Economic Review*, 45, 1-28.

- Li, H.Y. and H.F. Zou, 1998, "Income Inequality is not Harmful to Growth: Theory and Evidence" *Review of Development Economics*, 2, 318-334.
- Lundberg, M. and L. Squire, 2003, "The Simultaneous Evolution of Growth and Inequality," *Economic Journal*, 113, 2003, 326-344.
- MaCurdy, T., 1981, "An Empirical Model of Labor Supply in a Life Cycle Setting," *Journal of Political Economy*, 89, 1059-1085.
- OECD, 2004. *OECD Observer 2004*, OECD, Paris.
- Perotti, R., 1996, "Growth, Income Distribution, and Democracy: What the Data Say," *Journal of Economic Growth*, 1, 149-187.
- Persson, T. and G. Tabellini, 1994, "Is Inequality Harmful for Growth?" *American Economic Review*, 84, 600-621.
- Romer, P.M., 1986, "Increasing Returns and Long-Run Growth," *Journal of Political Economy*, 94, 1002-37.
- Saint-Paul, G. and T. Verdier, 1993, "Education, Democracy, and Growth," *Journal of Development Economics*, 42, 399-407.
- Turnovsky, S.J., 2000, "Fiscal Policy, Elastic Labor Supply, and Endogenous Growth," *Journal of Monetary Economics*, 45, 185-210.
- Viane, J.-M. and I. Zitcha, 2003, "Human Capital formation, Income Inequality, and Growth," in *Inequality and Growth: Theory and Policy Implications*: T.S. Eicher and S.J. Turnovsky (eds.), Cambridge MA: MIT Press.
- Vissing-Jorgensen, A., 2002, "Limited Asset Market Participation and the Elasticity of Intertemporal Substitution," *Journal of Political Economy*, 110, 825-54.
- Wolff, E.N., 1998, "Recent Trends in the Size Distribution of Household Wealth," *Journal of Economic Perspectives*, 12, 131-50.